



UW 1058

Ultimate Woofer,
 Ø 10", Ø 5.1" voicecoil, 8Ω



SPECIFICATIONS

General Data		
Overall Dimensions	DxH	263mmx148.5mm(10.35"x5.84")
Nominal Power Handling (DIN)	P	500W
Transient Power 10ms		1500W
Sensitivity 2.83V/1M		85.8 dB SPL
Frequency Response		See graph
Cone Material		Composite cellular fiber
Net Weight	Kg	6.1
Electrical Data		
Nominal Impedance	Z	8Ω
DC Resistance	Re	6.8Ω
Voice Coil Inductance @ 1KHz	LBM	1.33mH
Voice Coil and Magnet Parameters		
Voice Coil Diameter	DIA	130mm (5.1")
Voice Coil Height		37mm (1.45")
HE Magnetic Gap Height	HE	12mm (0.47")
Max. Linear Excursion	X	± 12.5mm (0.49")
Voice Coil Former		Aluminum
Voice Coil Wire		Hexatech™ Aluminum
Number Of Layers		2
Magnet System Type		High flux double ferrite vented
B Flux Density	B	0.64 T
BL Product	BXL	15.3 N.A
T-S Parameters		
Suspension Compliance	Cms	0.24mm/N
Mechanical Q Factor	Qms	1.72
Electrical Q Factor	Qes	0.58
Total Q Factor	Qts	0.43
Mechanical Resistance	Rms	11.691Kg/s
Moving Mass	Mms	99.3 g
Eq. Cas Air Load (liters)	VAS	40.8 Lt
Resonant Frequency	Fs	26 Hz
Effective Piston Area	SD	346 cm ²

- ### FEATURES
- * Uniflow™ Aluminum diecast chassis
 - * High flux double Ferrite magnet system
 - * 5.1" Large Hexatech™ Aluminum voice coil
 - * One piece paper cone/center dome
 - * Accucenter™ self centering cone assembly
 - * PFS™ Progression Field Symmetry spider/surround engineering

Unit Dimensions

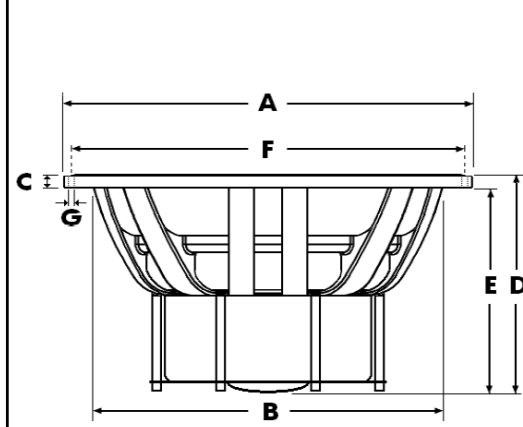

- A** - Overall diameter 263mm
- B** - Cut out diameter 241mm
- C** - Flange thickness 6.5mm
- D** - Overall height 148.5mm
- E** - Basket/magnet depth 142mm
- F** - Mounting holes location diameter 253mm
- G** - 6 Mounting holes, at 60° interval, inner hole diameter Ø 5mm

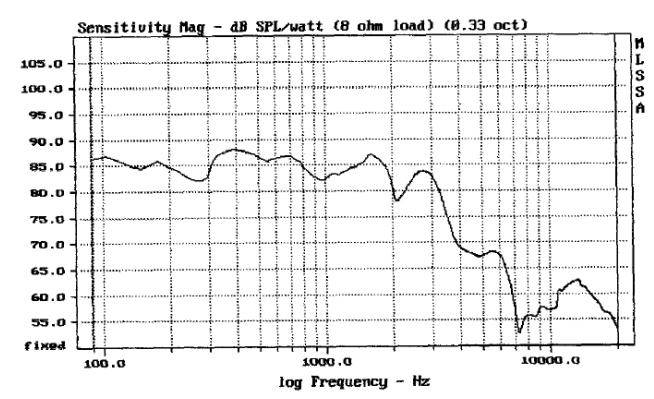
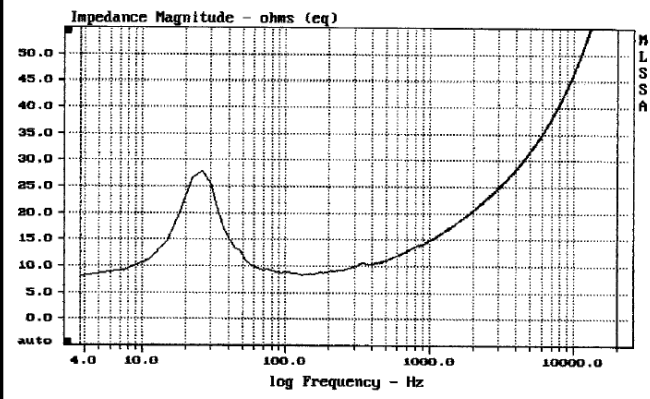

Measured on IEC baffle using Bruel & Kjaer 3144 model microphone.
 Morel operate policy of continuous product design improvement, consequently specifications are subject to alteration without prior notice.